

DO NOT SCALE DRAWING - IF IN DOUBT ASK

★ INLET CONNECTION MUST BE SUITABLY GUARDED BY CLIENT TO PREVENT OPERATOR ACCESS TO ROTATING PARTS IN LINE WITH RELEVANT SAFETY REGULATIONS (SEE BS EN 294/BS5304:1988).
NET WEIGHT OF M/C=380 kg

★ #6 OD PUSH-IN TUBE BULKHEAD CONNECTOR FOR SEAL PURGE, REQUIRES REGULATED SUPPLY OF CLEAN+DRY AIR/GAS(INERT) AT 0 TO 15 psig.(0 TO 1 bar.) 0.17 TO 0.7 cu.ft./min.(5 TO 20 lt./min.)

ACCESS FOR SAFETY INTERLOCK & MOTOR WIRING UNDERSIDE OF PLATE WITH A CABLE ENTRY GLAND M32 X 1P.

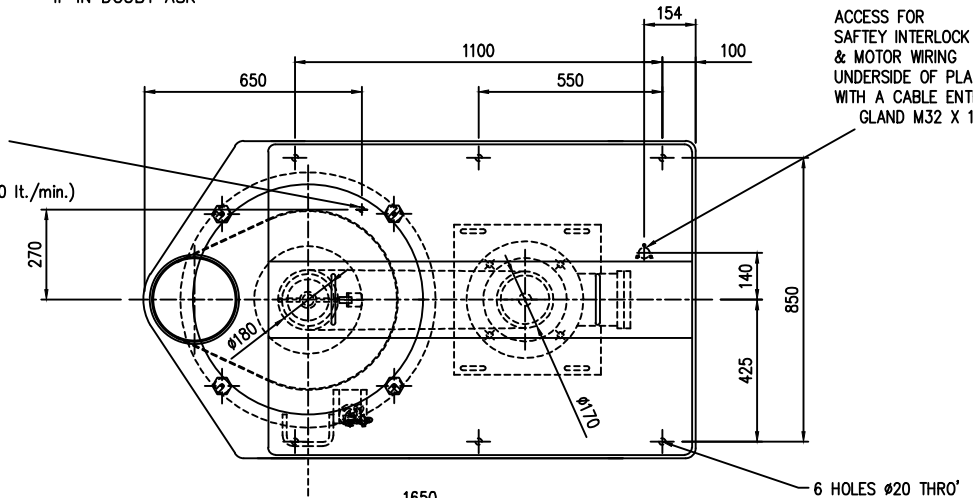

DISCHARGE CHUTE SAFETY INTERLOCK MUST BE WIRED INTO MOTOR CONTROL CIRCUIT (BY CLIENT) TO PREVENT MOTOR RUNNING, OR DE-ENERGISE MOTOR IF ALREADY RUNNING, SHOULD THE INTERLOCK BE ACTUATED BY THE CHUTE BEING SWUNG OPEN.

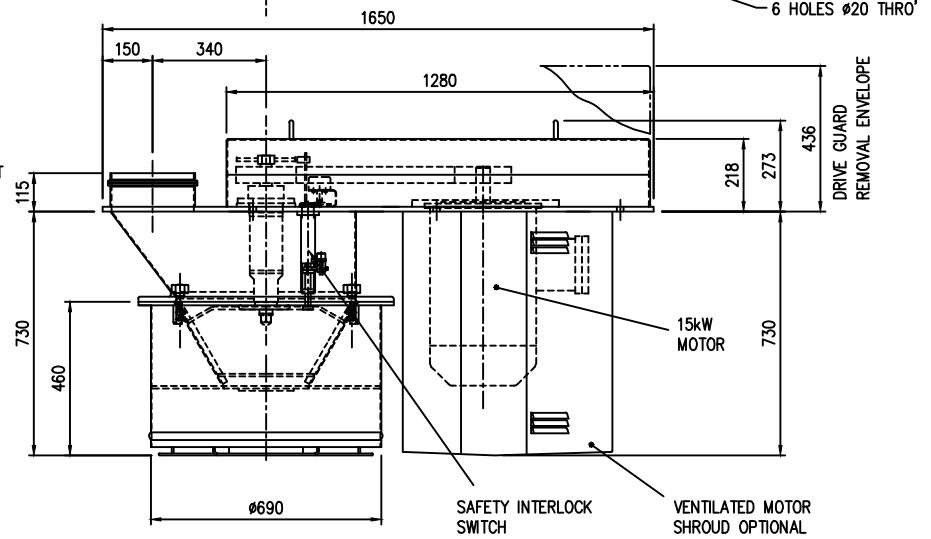
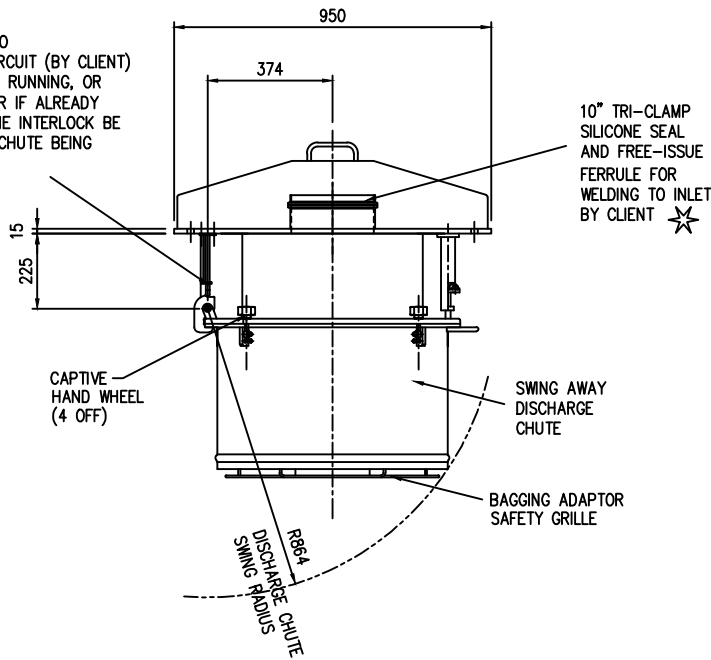

	Kemutec Powder Technologies Ltd Springwood Way, Macclesfield Cheshire SK10 2ND Tel: +44 (0)1625 412000 Fax: +44(0)1625 412001 Email: sales@kemutec.com Web: www.kemutec.com	DRAWN BY E HOWE
		CHECKED BY
TITLE 540 CONE MILL		APPROVED BY
DRAWING No A4 DS486		SCALE 1:10
ISSUE A		DATE 07/07/99

THIS DRAWING IS THE PROPERTY OF KEMUTEC POWDER TECHNOLOGIES LTD AND MUST NOT BE COPIED OR SHOWN TO A THIRD PARTY WITHOUT THE WRITTEN CONSENT OF THIS COMPANY. ©	DRAWING SPECIFICATIONS UNLESS OTHERWISE STATED Screw threads to BS3643 ISO Metric Coarse Pitch Series (Medium Fit) Surface Finish to BS1134 in micrometres Welding Symbols to BS499 Part 2 Dimension & Geometrical Tolerances to BS308 Limits & Fits to BS4500 Remove all sharp edges and burrs	TOLERANCE SPECIFICATIONS UNLESS OTHERWISE STATED SHEET METAL DIMENSIONS 0 to 300 ± 0.20 300 to 1000 ± 0.30 Over 1000 ± 0.50 UNMACHINED DIMENSIONS 0 to 100 ± 0.30 Over 100 ± 0.50 ANGULAR DIMENSIONS ± 0°-30'	ALL DIMENSIONS IN MILLIMETRES THIRD ANGLE PROJECTION ©
	For all material, weld and finish specifications refer to purchase/works order unless stated otherwise		